



RELIABLE MEMBRANE SAMPLING FOR ON-LINE ANALYSIS

New technology developed by Dow Chemical (US Patent 5,317,932) and licensed to FIA Solutions, Inc. provides a robust and reliable method for sampling difficult process streams.

Until now, the use of pervaporation sampling using membranes has been frustrated by the relative fragility of membranes. To obtain the best mass transfer kinetics, it is desirable to use very thin-walled membranes. Unfortunately, such thin walls lead to ease of rupture or other damage to the membrane. In addition, thin-walled tubing is difficult to coil without collapse of the walls. The new device allows use of very small diameter (and thus thin-walled) tubular membranes, while supporting and protecting the membrane tube in such a manner as to prevent the problems normally associated with such thin membranes. In addition, the new device allows the use of membrane tubes of great length (typically 2 meters, but possibly greater). The greater membrane length allows mass transfer kinetics that reach vapor-liquid equilibrium inside the tubing, simplifying calibration and yielding accurate quantitation.

SUPPORTED CAPILLARY MEMBRANE SAMPLING PROBE

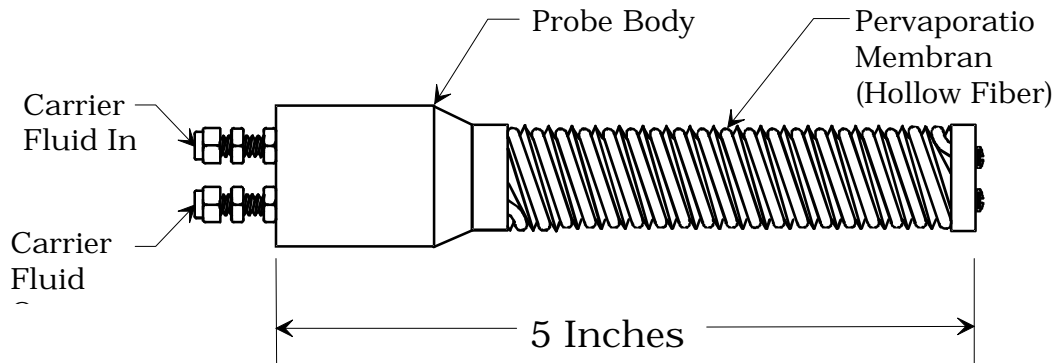

FIGURE 1

The new device is the “Supported Capillary Membrane Sampling Probe” (SCMS), shown in Figure 1.



The unique geometry of the SCMS is a “single-ended” device, which can be used directly in process piping, as in Figure 2 below.

IN-PROCESS CONFIGURATION

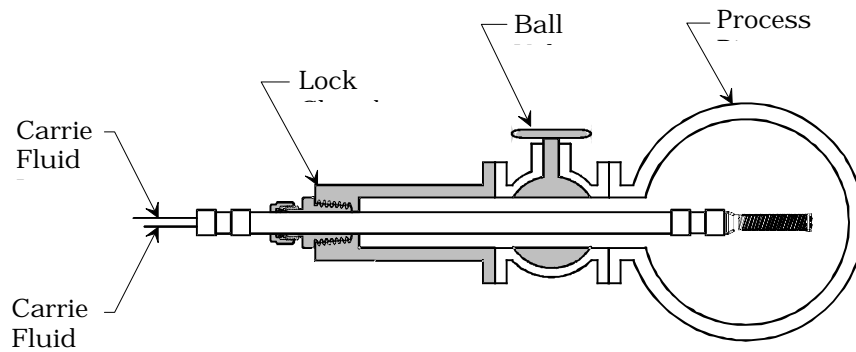

FIGURE 2

The identical SCMS device fits a 1” tubing fitting, and can also be used in a flow-cell configuration when instrumentation must be mounted at greater distances from the process line (as in “analyzer houses”), and the sample must be pumped to a central location (FIGURE 3).

FAST-LOOP/FLOW-CELL CONFIGURATION

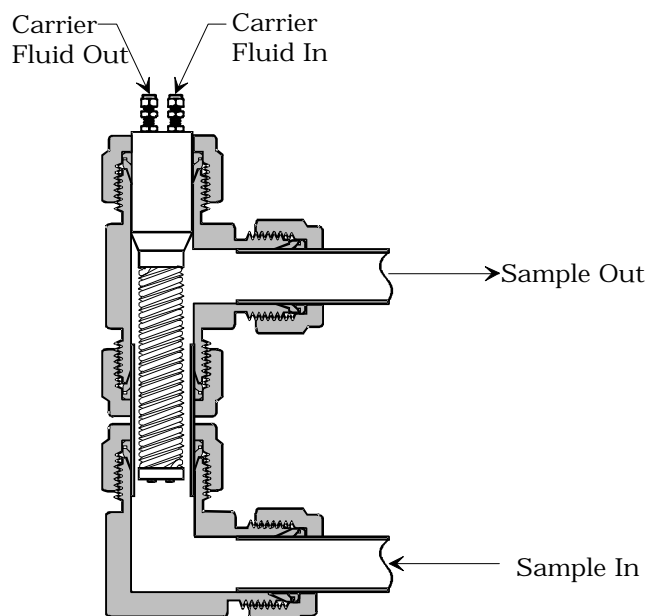

FIGURE 3

The widest application of the SCMS to date has typically been as a sampling system for volatile and semi-volatile analytes with analytical finish by gas chromatography. In practice, a carrier gas (typically nitrogen) is purged through the inside of the tubular membrane of the SCMS, into the sample loop of the injection valve. The constant-volume gas phase aliquot is injected onto the GC column for separation and analysis.

Examples of organic analytes sampled in process streams with the SCMS include chloroform, 1,3 butadiene, acetaldehyde, acetone, and benzene.

Of course, the SCMS is by no means limited to this type of sample, or this particular analytical finish. It is quite possible to use the SCMS with liquid-phase carrier (for analysis of non-volatiles), or perhaps with chemically reactive carriers (for analysis of specific analytes by highly selective wet-chemical methods). One very interesting approach is to use a water carrier, with injection of a constant-volume aliquot of a color-forming reagent. As the reagent aliquot



P.O. Box 2297 • Gig Harbor, WA, 98335 • Phone 253-265-8586 • Fax 253-265-8587

traverses the membrane, sample molecules partition from the membrane inner wall to the reagent, and react. This allows one to selectively analyze molecules like SO₂, NH₃, Cl₂, etc. with high specificity and sensitivity, yet very minimal reagent usage.

The membrane sampling approach eliminates problems from dissolved solids, high levels of salts, high levels of suspended particulate, etc., which have been the bane of reliable on-line sampling.

Typical lifetimes of SCMS membranes in continuous service are a year or better.